

ADVANTAGE 3X4 POP UP ASSEMBLY INSTRUCTIONS

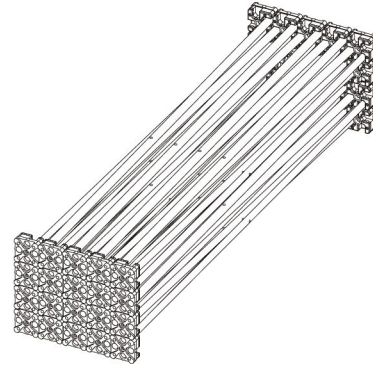

1 Unpack the collapsed frame from the drawstring bag.



2 Extend the frame

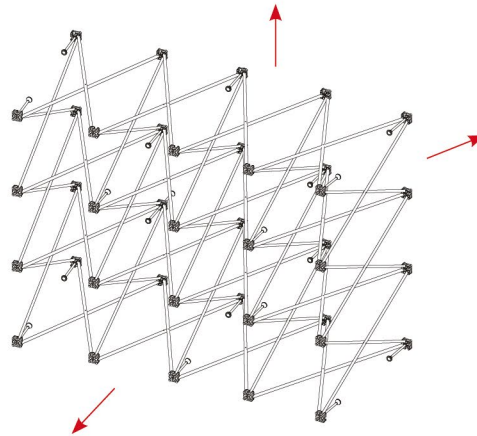

3 Magnetic locking arms will engage at full extension

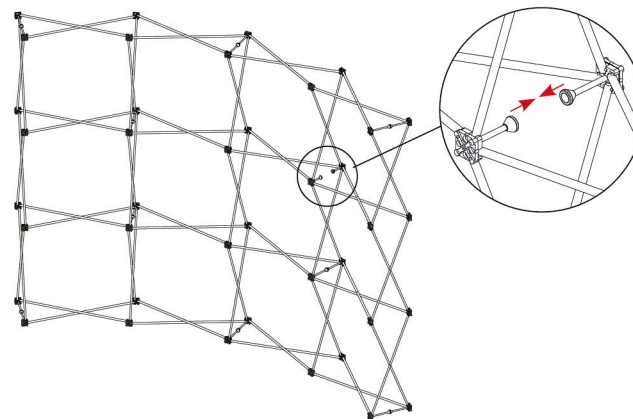

4 Attach magnetic bars to nodes

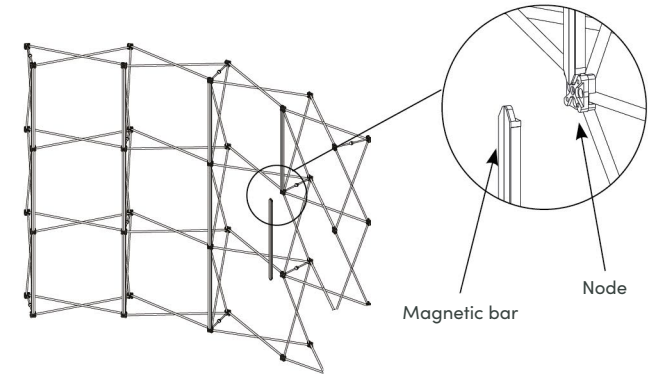

5 Attach panels in sequence, starting from either the left or right. Locate magnetic hanger onto nodes and allow panel to roll down magnetic bars.

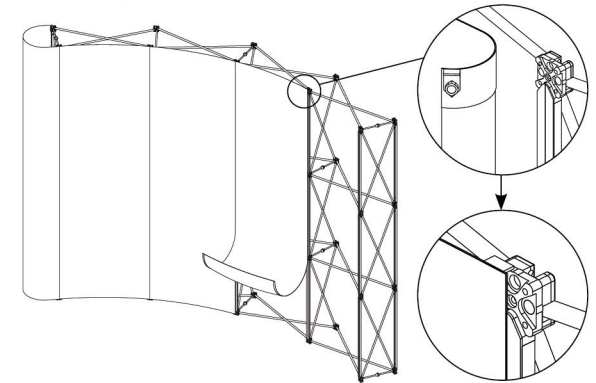

6 Assembled pop up system

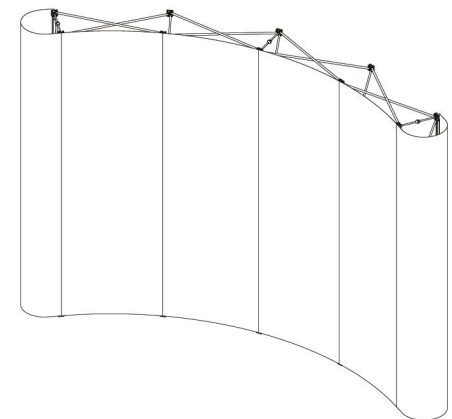

ADVANTAGE FOOTPRINT DIAGRAM

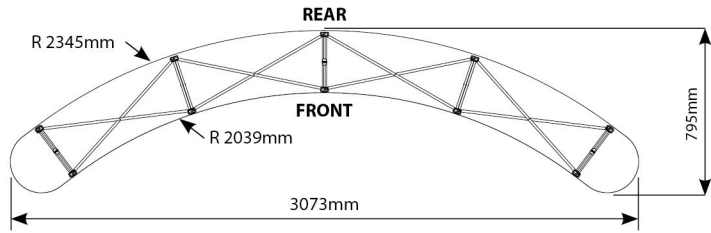

GRAPHIC ATTACHMENT INSTRUCTIONS

INNER CURVE PANELS (2130 x 653mm) /
REAR CURVE PANELS (2130 x 757mm)

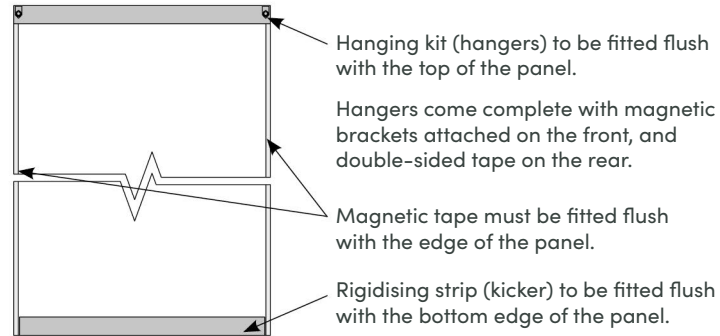

'D' END PANEL (2130 x 653mm)

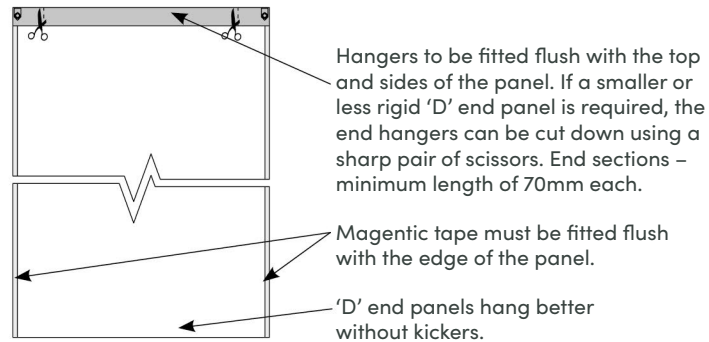

STORMPRESS

Call 01392 660099

Email sales@stormpress.co.uk

Web stormpress.co.uk

LECTURN WRAP ASSEMBLY INSTRUCTIONS

FABRIC WRAP

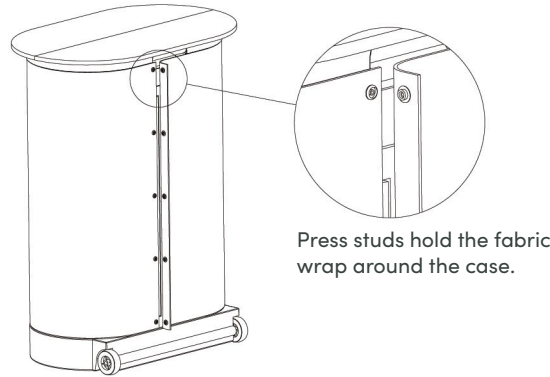

GRAPHIC WRAP

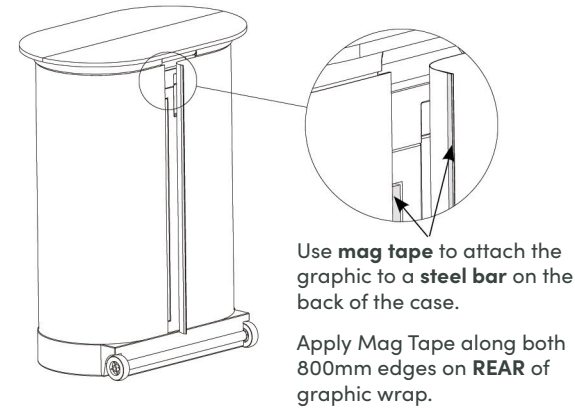

CASE LID LIGHTING STORAGE

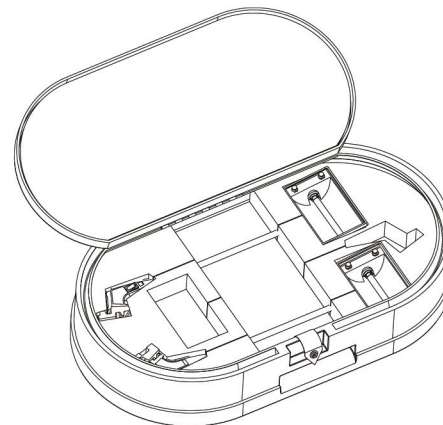

LIGHT FITTING INSTRUCTIONS

